

Optimal Placement of Micro Distribution Generator in Micro-Grid for Loss Minimization Using PSO

Shiva Pujan Jaiswal, Sharda University, India*

Ibrahim Abdulhamid Datti, Sharda University, India

Mustapha Muhammad Saidu, Sharda University, India

K. Jayachitra Chitra, Sharda University, India

ABSTRACT

The major aim of DG optimal placement is obtaining the best DGs units sizes and locations so as to have optimum operation and planning of the distribution network system while considering DG capacity constraint. This paper addresses the issues related to the improvement of voltage profile and power loss reduction by integrating DG units. The technique was applied to optimally placed optimum DG unit size in distribution systems for the improvement of candidate bus voltage and reduction of power loss in the system. The technique proposed was simulated on IEEE-10 bus and IEEE-13 bus standard test system, and the obtained results show that the proposed method is strong and effective for optimal placement of DG units.

KEYWORDS

Distributed Generation, Optimal Placement, Optimal Size, Particle Swarm Optimization, Radial Distribution System

1. INTRODUCTION

The availability of renewable energy resources in developing countries is playing a decisive role in the economic growth of the nations; recent studies have shown that there is a positive relationship between the levels at which the countries are developing and the level at which their energy consumption is increasing (Timothy,2020). The present world's energy reserves are very limited; therefore it's quite impossible to continue relying solely on existing conventional sources of energy. With everyday increasing energy demands and abrupt reduction in fossil fuel, the need for a cleaner environment and reduction in greenhouse gases emissions enhance the necessity of DG(Vikas,2016). The use of distributed energy resources has over the years brought many incentives as a result of changes in the generation and transmission paradigm. DG resources more specifically the ones with facilities based on the recent technologies (PV Arrays, wind energy, fuel cells, micro-turbine, etc.) have a significant role in supporting the available energy supply to meet demand. DGs involve small capacity power that sizes not less than 10kW up to 10 MW that is usually connected at major load centers (Mustapha, 2020).

DOI: 10.4018/IJEOE.309418

*Corresponding Author

This article published as an Open Access Article distributed under the terms of the Creative Commons Attribution License (<http://creativecommons.org/licenses/by/4.0/>) which permits unrestricted use, distribution, and production in any medium, provided the author of the original work and original publication source are properly credited.

Utility are been economically penalized due to high losses in the system (if the losses go beyond the standard limit) whereas it makes a profit if the losses are less. In addition to that, the efficiency of energy transmission to the end-users is significantly reduced as a result of high active power loss in the MG (Shashank,2020). Hence, active power loss drop has gained more attention from utilities. Also, reactive power loss reduction is an important objective of DG optimal placement. Furthermore, distribution system planning by optimal placement helps in reducing resistive (I^2R) and imaginary (I^2X) losses as well as drops in the voltage magnitude level in the distribution network. These utilities are now seeking recent technologies that will provide highly efficient, reliable, and high-quality power to their customers in a restructured power industry. This brings rapid and continuous development in DG integration globally; this is because of its smaller size, low cost, and high potentiality of lesser environmental impacts (Pandian, 2018).

The main motivation to carry out this work is that lower the efficiency of Micro Grid (MG), and to improve it DG plays a vital role. With DG the MG owners will have an access to the DNS as an independent energy producer. MG with DG units to provide better efficiency of the systems and guaranteeing adequate security and reliability levels. But the integration of DG into the systems also increases the level of uncertainties involves in the systems planning and operation. Hence, the need for suitable methods to be developed to study and predicts system's performance. Several factors need to be defined for the design of MG with DG units, these factors include, the preeminent technology to be used, the capacities of the DG, its number, its location, and network connection methods, etc. The DG has many impacts on the systems operating behavior such as power losses, system reliability, voltage profile, environmental impacts, and many more. Hence these impacts need to be carefully evaluated. Therefore these motivate the authors to come with this methodology for the best position and optimum capacity of DG in MG.

This manuscript presents a novel technique by applying PSO along with Backward/Forward sweep load flow analysis to determine the optimal size and site of DG in the MG by using the PSO algorithm. A fitness function is developed, mitigation of power loss is considered as the objective, and bus voltage profile improvement is treated as a constraint of the optimization function. The developed technique is validated on the IEEE-13 bus and IEEE-10 bus standard radial test systems.

The manuscripts systematized as follows; introduction of the concept is discussed in the first section, in the second section a detailed review of past works related to DGs optimal placement in distribution systems were presented, then the general overview of the proposed methodology is given in the third section, in which the first part contains an overview of the LFA techniques and the second part is about the PSO techniques and finally the last part is about the application of the proposed technique for DG placement. Section 4 contains problem formulation for the proposed method, and in section 5, a detailed discussion of the results obtained from testing of the proposed techniques on IEEE standard bus systems was presented and analyzed. Finally, in the last 6th section, a detailed conclusion based on the results obtained is presented.

2. LITERATURE REVIEW: DG PLACEMENT TECHNIQUES

In current era, the field of optimum DG placement is becoming an area of interest to many power system engineers and researchers because of its numerous benefits. One of the benefits of optimal DG placement is that it gives the utility operators the ability to regulate and control system parameters such as voltage profile of the systems, improve power quality, and perform peak demand shaving, better the reliability of the system, also other than its operational benefits in the MG, proper placement of DG has a crucial role on environmental impacts (Pandian,2019). Therefore, optimum sizing, best location as well as continuous monitoring of DG must be taken into account. In power distribution systems, proper placement of DG has a crucial role in environmental impacts. Therefore, optimal placement and sizing as well as continuous monitoring must be taken into account (Pandian, 2020).

Reference (Vikas, 2017), provided a comprehensive report on grid reconfiguration. In this paper, the authors considered several important factors to form multi-objective functions and evaluate reliability. A simple analytical approach based on conventional iterative search techniques and NR Load flow methods was implemented to obtain a proper position and capacity of DGs in a network (Georgilakis, 2013). The objectives of this work are minimizing the losses and costs of the systems. An improved analytical method was applied to obtain a Lagrangian multiplier associated with the active power flow equation (Thakar, 2019). This paper provides DG placement considering its size and location for maximum benefits in the network. Another classical method is proposed in (Ghosh, 2010) by using novel and improved methods for DG placement and sizing. But the analytical methods are quite complex and require many iterations before reaching the optimum value, so many researchers started to apply other techniques of optimization such as swarm intelligence-based PSO, meta-heuristics techniques, and ANN-based for improving system performance (Shiva, 2018).

Because of the uncertainties in the operation of DGs and the stochastic and probabilistic nature of MG planning and operation, many scholars applying optimization algorithms that are based on Artificial Neural Network (ANN) techniques which can be used for the prediction of the system behavior and planned for the best DG size and capacity. In (Veeresh, 2021) ANN methods are applied to predict the output power of DG units considering the DG's uncertainties and stochastic behaviors for optimal placement and sizing of the DGs in distribution grid. The authors of (Gampa, 2015) applied ANN Based method that uses a multi-objective approach that will predict the power output of the DG units while considering investment and stochastic behaviors of the DG. Also, the authors consider voltage stability index and various load models. In (Phonrattanasak, 2010), a multi-objective optimization algorithm was formulated and solved for determining ideal DG unit's capacity and location, taking into consideration both technical and economic factors such as line load and reduction of power loss, and improvement of voltage profile and investment cost. The author (Babu,2020) uses a novel index of sensitivity that is based on load and sensitivity based on the system voltage to identify the optimal DG unit's location and size that will operate at unity using a Genetic Algorithm (GA) for different load levels. A method (Katyara,2021) based on a fuzzy-satisfying interactive procedure that uses a hybrid modified shuffled frog learning to solve a multi-objective problem for optimum capacity of DG and its location in grid, with the main objectives of minimizing system loss, cost, and pollutants emission produced by the systems. In (Devi, 2014), Bacterial Foraging Optimization Algorithm (BFOA) was utilized for reduction of electrical losses and voltage profile improvement by optimally placed DG in a network. Although the BFOA is a very popular optimization technique for solving complex problems but its time consuming as its convergence speed is quite low.

In (Gangwar,2021) considers three objectives namely; Voltage deviation index, Active power loss index, and line load index in solving a multi-objective for optimal DG placement using Non dominated Sorting Genetic Algorithm(NSGA)-II together with the Fuzzy Satisfying Method (FSM). The proposed method doesn't consider proper sizing of DG, but it will help in achieving the goal of maximum DG installation in a network. Other meta-heuristics methods that were used for optimum sitting and sizing of renewable resource based DG (Murty, 2019) used unpredictable load models using fusion optimization for minimization of power loss of grid. Authors (Qiangda,2012) proposed a Bat Algorithm with varying load for optimal sitting and sizing of DG units in the system. The main objectives of this work are power loss minimization and voltage stability index maximization within limits.

A technique was developed (Yuliiia, 2021) to improve the technical as well as the economic benefit of DG installation; it was also based on a hybrid optimization technique comprising the application of PSO and GA. A multi-objective fitness function is optimized considering some technical factors which include indices of active power loss and reactive power loss, voltage deviation index, and system reliability index for better performance. But this method is also complex and requires a lot of iterations. Authors (Devineni,2021), present GA based technique to conclude the optimum size and

bus number of DG in MG by solving a multiobjective function which includes minimizing power loss of the grid, improvement of voltage regulation, and voltage stability. Another hybrid technique based on PSO was proposed by (Vikas, 2020) for optimum DG sizing and its location in the MG, this method is also used a solo objective for minimization system loss. PSO and simple algebraic modeling (Same 2019) as used to model a grid, to find the optimal MG reconfiguration. In this work, PSO is applied to improve the voltage profile of the systems. The distribution system was modeled using an iterative procedure of a sweeping process for load flow and then applied PSO to find the optimum DG sizing and position with a single objective of minimizing losses of the system. The authors (Same 2019) applied the PSO technique to maximizes benefits and minimize the cost of the system operation by integrating DG into the distribution system. Authors (Seshu, 2021) integrated MG with three DGs (wind turbine, solar PV, and Micro-turbine) as the source of energy, battery storage, and flexible and fixed loads, applies PSO to optimize the energy cost of MG by best capacity and positioning of the DG in MG network. But this method was only applicable to small capacity MG with a few numbers of busses, and it also considers only active power loss without considering other technical factors. Authors (Roslan, 2020) also formulate a PSO based fitness function with objectives of minimizing the economic and emission costs of the whole system. Table 1 presents a summary of previous works reported in literature.

Table 1. Summary of the reviewed works

SI No.	Ref	Approach	Contributions	Methods Applied
1	(2)	Analytical search	power loss reduction for cost minimization	Placement and sizing of DG
2	(8)	Simple analytical	Voltage improvement and Power loss minimization	DG sizing and placement
3	(9)	Analytical search	Power loss reduction	DGs placement and sizing
4	(10)	LMP	Social welfare and profit maximization	Only placement of DG
5	(11)	NSEA-II & FSM	APLR, Voltage profile improvement, and line load loss reduction	DG placement
6	(14)	ANN	Active power loss reduction and minimization of costs	DERs (DGs and ESS) Placement and sizing
7	(15)	ANN	Loss reduction	Placement and sizing of DGs
8	(16)	MPSO	System emission and economics costs minimizations.	DGs placement
9	(18)	FSM and FLA	Minimization of losses, cost, and pollutants	DG units placement and sizing
10	(19)	BFOA	improvement of profile of voltage and mitigation of Loss	DG units placement and sizing
11	(21)	CSA	losses saving and uniform voltage profile	Placement and sizing DG
12	(22)	BAT	Maximizing technical benefits of DGs installation	Placement and sizing DG
13	(23)	GA and PSO	improvement of profile of voltage and mitigation of Loss	Placement and sizing DG
14	(24)	GA and PSO	Reduction of Line loss and voltage profile improvement	DG units placement
15	(25)	BPD	Minimization of power loss	DGs placement
16	(26)	PSO	Maximization of annual cost savings and minimization of power loss and	Micro-grid reconfiguration
17	(12)	PSO	Voltage profile improvement	DGs allocation
18	(13)	PSO	Cost-benefit analysis for maximizing profits	DGs and Capacitors placement
19	(27)	PSO	Minimization of power loss	Placement and sizing DG
20	(28)	PSO	losses saving and uniform voltage profile	Placement and sizing DG

3. PROBLEM FORMULATION

The main objectives of this work are to bus voltage profile improvement and reduction of power losses as well as the reduction in the carbon emission by the optimization size and location of DG. The defined objectives of the paper are; perform LFA on the MG systems using the Backward/Forward Sweep algorithm and apply PSO techniques to obtain the best and optimum size and best location of DG in MG. This section discusses the concept of the Backward and Forward Sweep algorithm and the mathematical implementation of PSO for optimal DG placement.

3.1 Assumptions

Some of the assumptions made in this research work are to simplify the simulation and for critical analysis of the impact of DG installation in the MG (Tim, 2017) such as:

- MG was assumed to be a network.
- Load on the system is constant.
- Initial value of voltage magnitude is 1.0pu.

3.2 Backward/Forward Sweep Algorithm

The backward/forward sweeping process applies the unique features of the radial distribution system of having one specific path for the flow of power from the substation to any bus in the network. The forward sweep and the backward sweep are the two basic steps of the sweep algorithm. The backward sweep is a summation process of the current or power flows together with updates of the bus voltages. Whereas the forward sweep process used to calculate drop of voltage and power or current updates. The sweeping process is powerful in power distribution, it is achieved by using various methods which include; current summation, power summation methods. Algorithm for forward/backward sweeping:

1. Initialization of all bus voltages.
2. Backward sweep; add up all the power or currents flows (also possibly update voltages).
3. Forward sweep; compute voltage drops (and possibly updates currents or power flows).
4. Steps 2 and 3 should be repeated until a specified tolerance for convergence is achieved.

3.2.1 Power Summation Method

This method is given in detail in Figure 1 displays a single line representation of a radial distribution network. With consideration of real power P_k and reactive power (Q_k) flowing from node 'k' through $(k+1)^{th}$ node. Initially, a 1.0 pu flat voltage magnitude is assumed at each node.

3.2.2 Backward Sweep

The Power flow in each branch of the network is estimated in reversed/ backward direction from the terminal node, and this is giving by the equation (1):

$$P_k = P'_{k+1} + r_k \cdot \frac{(P_{k+1}^2 - Q_{k+1}^2)}{V_{k+1}^2} \quad (1)$$

where:

Figure 1. Single-line diagram of RDS

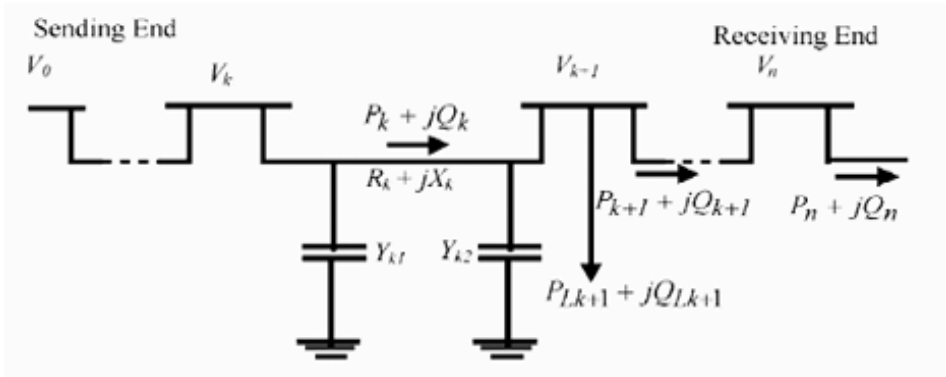

$$P'_{k+1} = P_{k+1} + P_{Lk+1} \quad (2)$$

$$Q'_{k+1} = Q_{k+1} + Q_{Lk+1} \quad (3)$$

P_{k+1} and Q_{k+1} are the effective flow of power from $(k+1)^{th}$ node and P_{Lk+1} and Q_{Lk+1} the connected loads at node $k+1$.

3.2.3 Forward Sweep

Using equation (4) below, the node voltage magnitude and phase angle at each node is then updated in a forward direction:

$$V_{k+1} = V_k - Z_k I_k \quad (4)$$

where I_k represent the branch current flows through branch 'k' and Z_k represents branch impedance of branch from node 'k' to node 'k+1'.

The backward and forward sweep methods equations are repeatedly continued up to the convergence is limit.

3.2.4 Current Summation Method

With the known magnitude of node voltage at the reference bus and a presumption of the initial voltages of each bus, the algorithm works with the following three steps at every iteration.

Step 1: Computing the Nodal current.

Equation (5) is used to determine the current injected at each node 'i' as:

$$I_i^{(k)} = \left(\frac{S_i}{V_i^{(k)}} \right) - y_i \cdot V_i^{k-1} \quad (5)$$

For $i = 1, 2, 3 \dots n$.

S_i represent the power at the i^{th} node, V_i^{k-1} gives the voltage at node i and y_i gives the shunt admittance at i^{th} node.

Step 2: Backward sweep.

This begins with the branch at the last end and the current flows J_i in branch 'I' is determined using equation (6):

$$J_l^k = I_{lr} + \sum J_{lr} \quad (6)$$

where, $L = b, b-1 \dots 1$.

I_{lr} represents the current injected at node lr , calculated in step 1, $\sum J_{lr}$ gives the currents in the branches starting from node I_r .

Step 3: Forward sweep.

Starting with the reference bus, the bus voltages are updated using equation (7):

$$V_{lr}^{(k)} = V_{ls}^{(k)} - Z_l J_l^{(k)} \quad (7)$$

For, $L = 1, 2, 3 \dots, b$.

I_s and I_r are the branch currents at the sending and receiving ends respectively, Z_l represents the source impedance of branch l .

3.3 Overview of PSO

PSO is an optimization algorithm that mimics the established swarms or colonies of insects such as ants, termites, bees, wasps, as well as a Bird's flock or a school of fish (Bishwajit, 2019). A particle from a population represents an ant in a colony, a bird in a flock, or a fish in the school. Each member of the swarm makes use of its intelligence as well as the collective intelligence of the group of the swarm. In a multivariable optimization algorithm; each member of the swarm is randomly located in a multidimensional design space. Every member of the swarm possesses its position and velocity in the search space and it can remember the best position that has been so far discovered. PSO makes use of the velocity vector in updating the particle's current position in the swarm. Based on the behavior of the individuals in the swarm, individual positions of the particles are updated. The particles become adapted to their environment by returning to the best-discovered regions (Jaiswal, 2020). The basic procedure for the implementation of the PSO algorithm is as follows:

1. Initializing the particle's population and their random positions and velocities on the problem space with d dimensions.
2. Evaluation of the desired fitness functions from the variables for each particle.
3. Comparing the value of fitness evaluation of the particles with its personal best (P_{best}). If the current value of the evaluation is better than P_{best} , then set the current value as P_{best} .
4. The evaluated fitness value is then compared with the previous overall best of the entire population (G_{best}), if this value is better than G_{best} then the current value is taken as G_{best} of the entire population.
5. Update the particle's velocities and positions using equations (8) and (9) respectively:

$$V_i = w * v_d + c_1 * rand(x_i) * (P_i - x_i) + c_2 * rand(x_i) * (g_i - x_i) \quad (8)$$

$$X_i = (x_i - v_i) \quad (9)$$

c_1 and c_2 are the acceleration constant which is used for weighting stochastic terms of the acceleration that directs each particle towards the positions of P_{best} and G_{best} . Hence, adjusting these constants reduces the stress of the optimization in obtaining the best solution. Lower values make the particles divert from target regions before been stocked and high values result in faster convergence of the process toward the intended location (Nitish,2019).

3.4 Implementation of PSO for Optimal DG Placement

The objectives function for the minimization of the power losses in the system under specified conditions and constraints. The objective function represents the total sum power losses at individual buses of the radial distribution systems and it's given in equation (10). The active power loss (P_{loss}) of the individual branches is calculated from the branch current (I) and the branch resistances (R) as $P_{loss} = I^2 R$:

$$fitness\ function = \sum_{i=1}^N P_{i,loss} \quad (10)$$

The maximum and minimum DG unit sizes are defined and from these defined sizes, particles' population size (N) is generated. The constraints to the objective function are given equation (11) and (12) which is arbitrarily considered to define the DG unit sizes limit as 60% of the system load with 0.95 power factor of the DG units and the voltage constraints are given in equation (13):

$$0 \leq P_{DG(size)} \leq 60\% * P_{Total\ load} \quad (11)$$

$$0 \leq Q_{DG(size)} \leq 60\% * P_{Total\ load} \quad (12)$$

$$0.95 \leq V_{bus} \leq 1.05 \quad (13)$$

For each particle from the N population, this objective function is evaluated, and then after initialization of the P_{best} , G_{best} , positions, and velocities of the particles are updated using equations (8) and (9) and then we update P_{best} and G_{best} .

w is obtained using the equation below:

$$w = w_{max} - \frac{w_{max} - w_{min}}{max\ iteration} * iteration\ number \quad (14)$$

The best solution is determined after defined iteration counts, the maximum iteration count used in this work is 1000 iterations. The inertial weight is varied continually at each iteration as in equation

(14). The maximum and minimum value of inertia (w_{max} and w_{min}) are respectively taken to be 0.9 and 0.4. Under given constraints of DG's positions, sizes, and voltages at individual buses and the system's losses, the best solution gives the minimum losses in the system.

4. RESULTS AND DISCUSSION

In this work, the simulations of the proposed method were carried out on IEEE-10 bus and IEEE-13 bus standard radial distribution systems. The results obtained from the simulation were presented in a tabular and graphical form that indicates the improvement in the system after optimal placing the DG.

4.1 DG Integration of IEEE-10 Bus System

The single line diagram of the IEEE-10 Bus system is shown in Figure 2 (Tyagi,2016), with bus number 1 as the reference bus at the starting point and no load connected to it. The reference bus is considered as the substation of the distribution network, and the voltage at this bus is always assumed to be 1.0 pu with zero power loss (Monika, 2017). The system total load is 2.6155 MW and 0.9984 MVAR which are distributed at different buses of the system with a maximum load of 0.456 MW and 1 MVAR at bus number 3.

After backward/forward load flow analysis, the result obtained is shown in stem plots of the voltage profile as shown in Figure 3. The plots of real and reactive power loss are presented in Figure 4. In the analysis, a base MVA of 100MVA is taken and 11KV as the base voltage value (Dung, 2016). A maximum voltage of 1.0 pu is found at bus number 1, and a minimum voltage of 0.9410 pu is found at the bus no 10. The bus voltages are gradually decreasing from bus 1 to bus 10. The system's total power loss is found to be 1.2119 MW (Prabha,2014). With 0.2295 MW maximum

Figure 2. IEEE-10 Bus standard test system

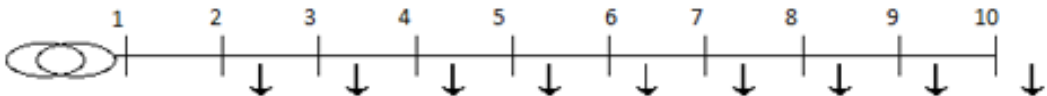

Figure 3. Voltage profile for IEEE-10 Bus system

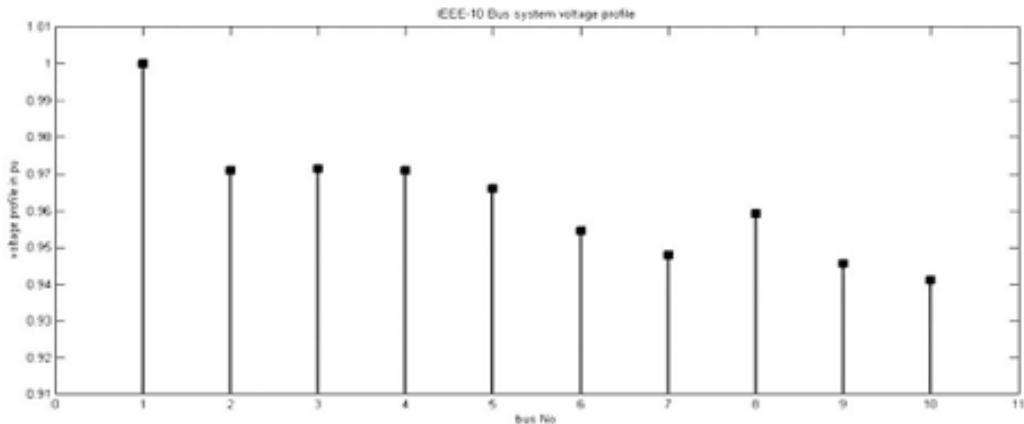
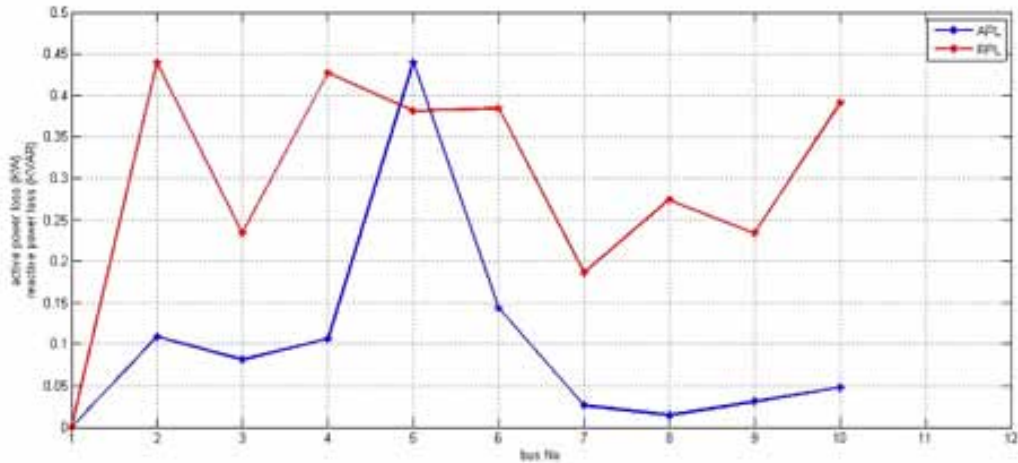

Figure 4. Real and reactive power of IEEE-10 Bus system



power loss found at bus 2. The branch current is also in decreasing order as there is variation in resistance and reactance of the branches and hence the I^2R and I^2X losses also varied for individual buses and lines.

After insertion of a DG in the MG using the developed technique. The optimal DG size is found to be 0.5 MW at bus no 3, as this gives the minimum losses in the MG and an improved voltage profile of the systems under given constraints. The maximum voltage magnitude per -unit is found at the reference bus and bus 10 has the minimum voltage of 0.9958 pu. Figure 5 presents the voltage profile improvement of the systems, and it's indicating that the system voltage profile has been improved significantly. The voltage profile of the systems as all bus voltages lie within the specified constraint limits and closed to 1.0pu. The Summary of system parameters with and without DG for IEEE-13 Bus is mention in Table 2.

Table 2. Summary of system parameters with and without DG

Bus No.	Without DG		With DG	
	Voltage profile (pu)	Active power loss (MW)	Voltage profile (pu)	Active power loss (MW)
1	1.0000	0.0000	1.0000	0.0000
2	0.9710	0.2295	0.9992	0.0622
3	0.9715	0.1802	0.9985	0.0585
4	0.9710	0.2041	0.9980	0.0817
5	0.9661	0.1118	0.9974	0.0652
6	0.9545	0.1757	0.9980	0.0710
7	0.9480	0.0734	0.9987	0.0465
8	0.9591	0.0797	0.9972	0.0685
9	0.9456	0.0907	0.9961	0.0335
10	0.9410	0.1427	0.9958	0.0353

Figure 5. Voltage profile improvement for the IEEE-10 Bus system

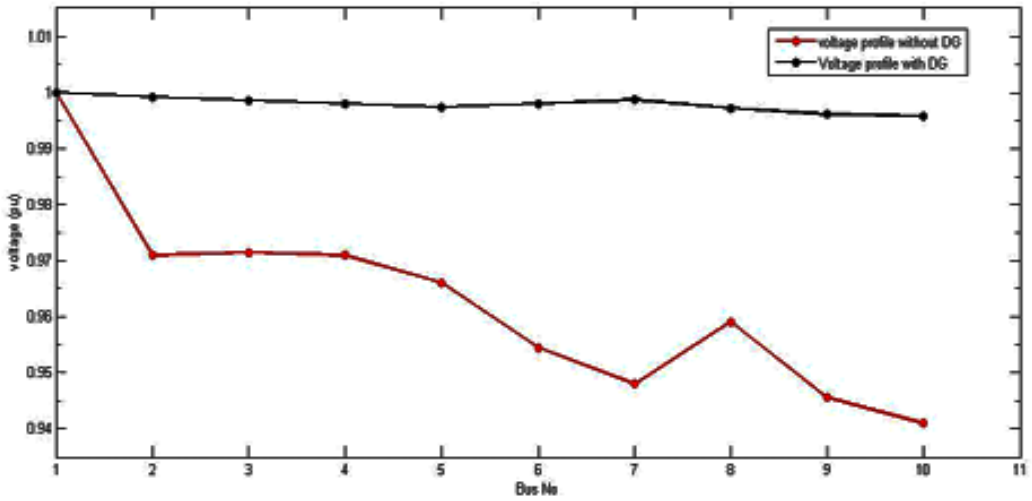

The reduction in the active power loss in the systems is presented in Figure 5, and it can be observed that the power losses in the system have been significantly reduced after placing the DG. After the placement of DG at bus number 3, there is almost 75% reduction in the power loss in the system and there is almost more than 60% reduction of power loss at bus numbers 3, 4, and 6. The maximum power loss is now 0.4390MW at bus number 3 and the new system’s total power loss is 0.577 MW this shows a 75% reduction in the system’s power losses.

A comparison of the results of the proposed technique with the existing result in literature is presented in Table 3. The results of the proposed methodology are compared with the Rigorous Method, Bacterial Foraging-Differential Evolution (BF-DE), Improved Harmony Search (HIS), and Plant Growth Simulation Algorithm (PGSA). The loss reduction by the PGSA method is more compare to the proposed, because of the high capacity of installed capacity, which required huge

Figure 6. Active power loss reductions for IEEE-10 Bus

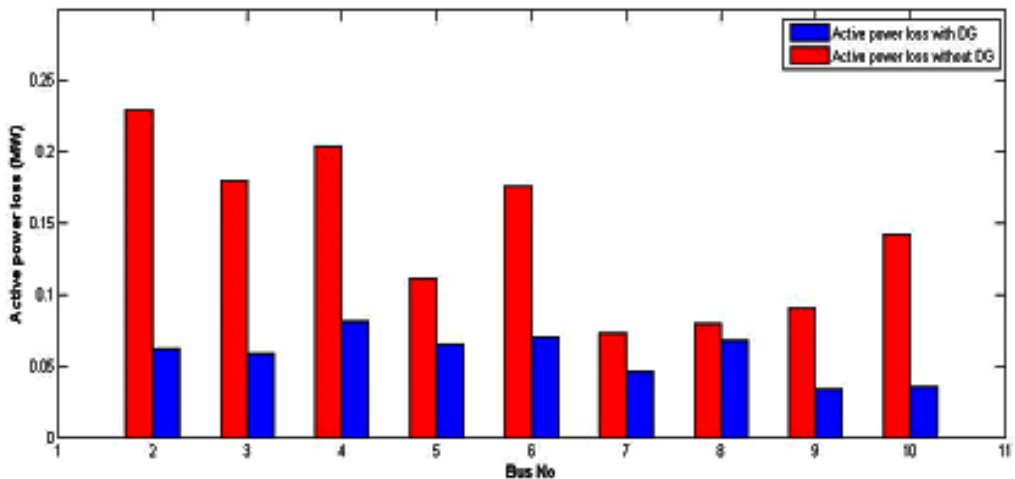

Table 3. Summary of system parameters with and without DG

Parameters	Algorithm				
	Rigorous Method (Tyagi,2016)	BF-DE (Tyagi,2016)	HIS (Tyagi,2016)	PGSA (Prabha,2014)	Proposed technique
Optimal DG Size (MW)	1.2	1.2	1.2	4.88	0.5 MW
Optimal DG location	6	6	6	9	3
% loss reduction	60.82	60.82	60.82	78.32	75
Minimum voltage (pu)	0.9560	0.9560	0.9560	0.9650	0.9958

installation costs. Whereas the bus voltage profile produces by the proposed technique best among the compared techniques.

4.2 DG Integration IEEE-13 Bus System

The IEEE-13 radial distribution test system single line diagram is shown in Figure 7(Elsaiah, 2014). It has 13 branches with bus number one as the reference bus, 1.0 pu fixed voltage is assumed with zero connected loads. The system has a total load of 2MW and 1.01MVAR (Phonrattanasak, 2010).

The load flow analysis (Backward/Forward sweep algorithm) is carried out on the systems with base values of MVA and voltages as 100 MVA and 11KV respectively. The system’s voltage profile is shown in Figure 8. The system’s maximum bus voltage is 1.00 pu at bus 1 (reference bus) and the minimum voltage of 0.9401pu at the 6th bus. It is observed that there are irregular changes in the voltages at every bus of the system. At bus number 11, 12, and 13 with voltage magnitude of 0.9441, 0.9422, and 0.9401 respectively has a lower voltage than the lower limit. The system’s total power loss is 2.6340MW, with a maximum loss of 0.3355MW at bus 7.

After simulating the developed technique on the system, the DG unit optimal size was found to be 0.9MW with the optimal location at bus 7. Figure 9 presents a comparison of the system’s voltage

Figure 7. IEEE-13 Bus standard test system

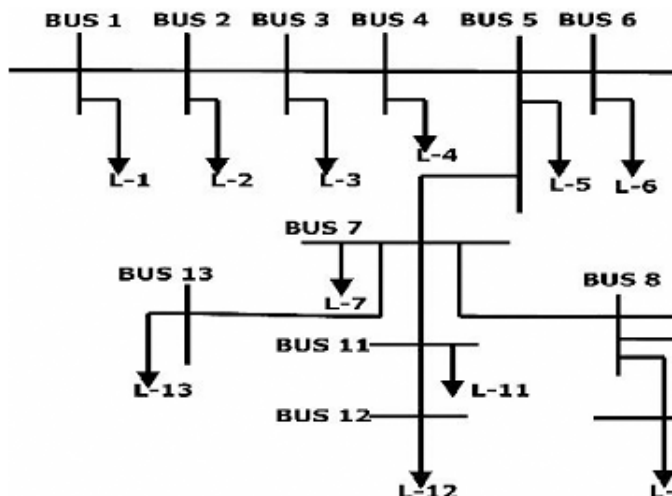

Figure 8. Voltage profile for IEEE-13 Bus system

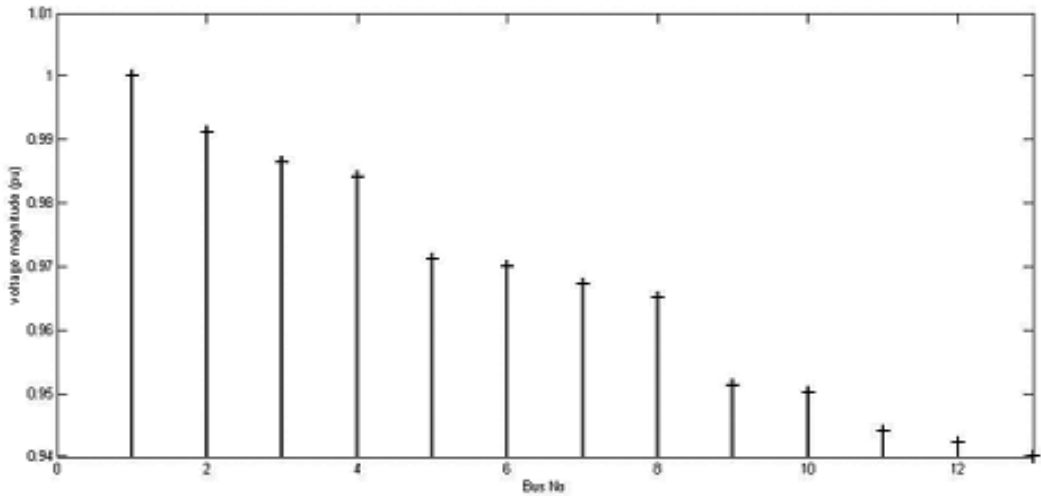
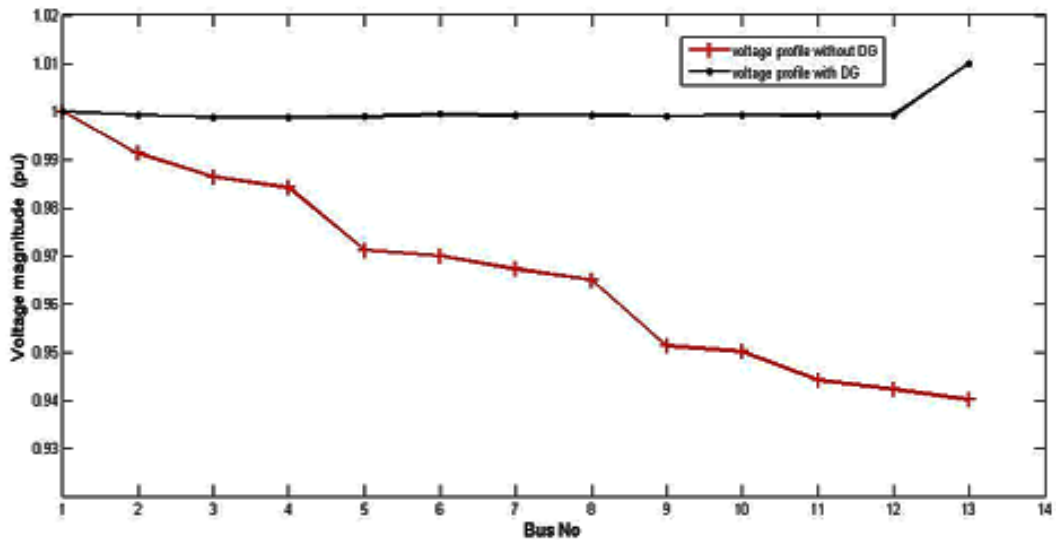

Figure 9. Voltage magnitudes with and without DG for IEEE-13 bus



profile before the integration of DG and after the placement of DG. Voltage profile has been improved after the placement DG unit also; the voltage magnitudes at individual buses are within limits. The maximum voltage is found at bus number 13 while bus 3 and 4 has the minimum voltages each of 0.9988pu which is much higher than the lower limit.

The active power loss at each bus, before and after the DG placement is shown in figure 10. Due to the optimal DG placement, the highest active power loss at the 7th bus is reduced from 0.3355MW to 0.0364MW which is almost a 74% reduction. Also at other buses of the system, there is a reduction in the real power loss after placement of the DG. Hence, the system's total power loss has been reduced by almost 70%. The Summary of system parameters with and without DG for IEEE-13 Bus is mention in table 4.

Figure 10. Active power loss reductions for IEEE-13 Bus system

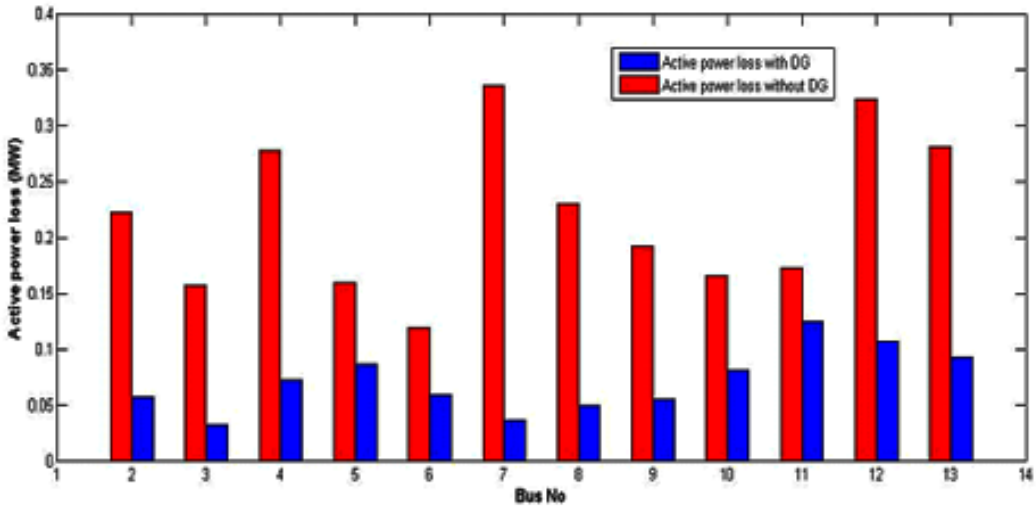

Table 4. Summary of system parameters with and without DG for IEEE-13 BUS

Bus No.	Without DG		With DG	
	Voltage profile (pu)	Active power loss (MW)	Voltage profile (pu)	Active power loss (MW)
1	1.0000	0.0000	1.0000	0.0000
2	0.9912	0.2225	0.9992	0.0572
3	0.9864	0.1570	0.9988	0.0322
4	0.9864	0.2780	0.9988	0.0725
5	0.9841	0.1590	0.9989	0.0865
6	0.9711	0.1185	0.9994	0.0593
7	0.9700	0.3355	0.9991	0.0364
8	0.9672	0.2300	0.9991	0.0500
9	0.9512	0.1915	0.9990	0.0545
10	0.9501	0.1655	0.9992	0.0815
11	0.9441	0.1725	0.9991	0.1246
12	0.9422	0.3220	0.9991	0.1074
13	0.9401	0.2810	1.0100	0.0928

A comparative study related to the placement of DG in the IEEE 13 bus system is given in Table 5. The results of the proposed methodology are compared with the GSA, LACPF, MPSO and, analytical techniques. The objective of the aforesaid algorithms is to minimize real losses or minimization of total power losses only whereas the proposed methodology considers the minimization of total losses as well as voltage profile improvement as constrain to optimize the objective function. Because of the consideration of voltage profile, the proposed technique provides a more uniform voltage profile as well as the highest percentage reduction in power loss.

Table 5. Comparative study in IEEE 13-Bus System

Parameters	Algorithm				
	GSA (Murty,2019)	LACPF (Elsaiah,2014)	MPSO (Babu,2020)	Analytical Phonrattanasak, (2010)	Proposed technique
Optimal DG Size (MW)	2.59	2.487	2.43	0.6569	0.9
Optimal DG location	6	6	6	7	7
% loss reduction	69.92	47.54	69.52	40.2	74
Minimum voltage (pu)	0.9424	0.9143	0.9700	0.9617	0.9988

4.3 Final Discussion

In the paper firstly the advantages and impacts of DG in a MG are examined, and then a objective function has been formulated, with power loss as objective along with voltage profile improvement as constrain. For optimization of place and size of DG, PSO has been integrated with forward and backward sweep method. An investigation of power loss and voltage stability in distribution network without DG and with DG has been carried out. The effectiveness of the proposed methodology is proved by validating it, on IEEE 10 bus and IEEE 13 bus radial network. The summary of the DG allocation with size, position, and the corresponding real power losses are presented in Table 2 and Table 3. The result indicates that proper DG placement reduces power losses in the system and also improves the voltage profile of the system. The voltage profile improvements of the IEEE-10 and IEEE-13 bus systems were represented in Figure 5 and Figure 9 respectively. Before the DG placement, after performing load flow analysis on the IEEE-10 bus system, three buses that are bus 7, 9, and 10 have a voltage magnitude that is lower than 0.95 pu. But after the DG was placed, these values are improved to meet the voltage regulation limit constraint. Similarly, in the case of the IEEE-13 bus system, the bus voltages at bus numbers 7, 8, 9,10,11,12, and 13 are improved after DG placement. The results of the proposed methodology in IEEE 10 bus system are compared with Rigorous Method, BF-DE, HIS, and PGSA as mention in Table 3. In the case of IEEE 13 bus system results are compared with the GSA, LACPF, MPSO and, analytical techniques. Because of the proper formulation of objective function and constrains, proposed PSO algorithm produce better results than reported technique.

4.3.1 Advantages of the Proposed Technique

- The proposed technique is more accurate, powerful, and efficient methods.
- It considers the most important technical factors of the DG placement such as bus voltage and power loss.
- It is easier to implement.
- It can be extended for future works.

4.3.2 Limitations of the Proposed Technique

This research work presents a noble approach for the optimal DG placement and sizing in the MG network with a single bi-objective of power loss reduction and a voltage profile improvement as constraints. The method considers only these two technical factors among the various technical

factor and economic factors related to DG placement. The PSO-based method is slow convergence and hence required much computation time. It also requires more memory.

4.3.3 Major Contributions in Research and Humanity

A consolidated effort has been made to improve the performance of the MG. The main aim of this research works to enhance the voltage stability and reduction of system loss. The PSO-based technique has been formulated to optimize the location and size of DG. Due to the reduction in the system losses and subsequent reduction in the power generation to serve the loss by central or conventional generation, i.e. environmental impact due to thermal generation has been reduced; hence low carbon emission due to optimal DG placement will lead to a cleaner environment. As well as the voltage profile was also improved after DG placement, i.e. the power quality of the system was improved and the system will have a better voltage regulation which will protect the utility as well as consumer's equipment and appliances from damages due to voltage fluctuations and poor voltage profile.

5. CONCLUSION AND FUTURE WORKS

This paper presented an algorithm based on the PSO technique together with an iterative load flow algorithm of backward/forward to optimize the size and location of DG units in MG for power loss minimization and voltage profile improvement. The proposed method is validated by IEEE-10 and IEEE-13 standard radial distribution test systems. The results obtained indicate that the system power losses have been reduced significantly and the voltage profile of the system is also improved. The results of the proposed technique are also compared with existing work. The obtained results prove that the developed technique is more efficient to reduce system power loss and make voltage profiles more uniform. The results obtained indicate the accuracy, effectiveness, and efficiency of the proposed technique. Some future extensions are also possible such as; involving time-varying loads, reconfiguration of grids, and multiple DG placements.

ACKNOWLEDGMENT

The authors are very grateful to Associate Professor, Dr. Vivek Shrivastava, Department of Electrical and Electronics Engineering, National Institute of Technology, Delhi, India for his valuable suggestions and critical examination of this work.

CONFLICT OF INTEREST

The authors of this publication declare there is no conflict of interest.

FUNDING AGENCY

This research received no specific grant from any funding agency in the public, commercial, or not-for-profit sectors.

REFERENCES

- Babu, P. V. K., & Swarnasri, K. (2020). Novel Technique for Optimal Placement and Sizing of DG in 3-Phase Unbalanced Radial Secondary Distribution System. *International Journal of Innovative Technology and Exploring Engineering*, 9(4), 1756–1760. doi:10.35940/ijitee.D1665.029420
- Bhadoria. (2016). *Optimal sitting and Sizing of Capacitor using Iterative Search Method for Enhancement of Reliability of Distribution System*. Advances in Energy and Power Systems, Lecture Notes in Electrical Engineering. doi:10.1007/978-981-13-0662-4_11
- Bhadoria, V. S., Pachauri, R. K., Tiwari, S., Jaiswal, S. P., & Alhelou, H. H. (2020). Investigation of Different BPD Placement Topologies for Shaded Modules in a Series-Parallel Configured PV Array. *IEEE Access: Practical Innovations, Open Solutions*, 8, 216911–216921. doi:10.1109/ACCESS.2020.3041715
- Bhadoria, V. S., Pal, N. S., Shrivastava, V., & Jaiswal, S. P. (2017). Reliability Improvement of Distribution System by Optimal Sitting and Sizing of Disperse Generation. *International Journal of Reliability Quality and Safety Engineering*, 24(6), 1740006. Advance online publication. doi:10.1142/S021853931740006X
- Daus, Y., Kharchenko, V., & Yudaev, I. (2021). Optimizing Layout of Distributed Generation Sources of Power Supply System of Agricultural Object. *International Journal of Energy Optimization and Engineering*, 10(3), 70–84. Advance online publication. doi:10.4018/IJEOE.2021070104
- Deogam, N., & Shabbiruddin, . (2019). Optimal Site Selection for Solar Photovoltaic Power Plant in North Eastern State of India using Hybrid MCDM Tools. *International Journal of Energy Optimization and Engineering*, 8(2), 61–84. Advance online publication. doi:10.4018/IJEOE.2019040104
- Devi, S., & Geethanjali, M. (2014). Application of Modified Bacterial Foraging Optimization algorithm for optimal placement and sizing of Distributed Generation. *Expert Systems with Applications*, 41(6), 2772–2781. doi:10.1016/j.eswa.2013.10.010
- Devineni, G. K., Ganesh, A., Naga Malleswara Rao, D. S., & Saravanan, S. (2021). Optimal Sizing and Placement of DGs to Reduce the Fuel Cost and T& D Losses by using GA & PSO Optimization Algorithms. *2021 International Conference on Sustainable Energy and Future Electric Transportation (SEFET)*, 1-6. doi:10.1109/SeFet48154.2021.9375701
- Dey, B., Bhattacharyya, B., & Sharma, S. (2019). Robust Economic Dispatch of Microgrid With Highly Penetrated Renewables and Energy Storage System. *International Journal of Energy Optimization and Engineering*, 8(1), 67–87. Advance online publication. doi:10.4018/IJEOE.2019010104
- Elsaiah, S., Benidris, M., & Mitra, J. (2014). Analytical approach for placement and sizing of distributed generation on distribution systems. *IET Generation, Transmission & Distribution*, 8(6), 1039–1049. doi:10.1049/iet-gtd.2013.0803
- Gampa, S. R., & Das, D. (2015). Optimum placement and sizing of DGs considering average hourly variations of load. *International Journal of Electrical Power & Energy Systems*, 66, 25–40. doi:10.1016/j.ijepes.2014.10.047
- Ganesan, T., Vasant, P., Sanghvi, P., Thomas, J., & Litvinchev, I. (2020). Random Matrix Generators for Optimizing a Fuzzy Biofuel Supply Chain System. *Journal of Advanced Engineering and Computation*, 4(1), 33-50.
- Gangwar, P., Keshwani, S., Chakrabarti, S., & Singh, S. N. (2022, June). Multiobjective Multiscenario Framework for RCS Placement in Unbalanced Distribution Systems Considering Uncertainty. *IEEE Systems Journal*, 16(2), 2811–2821. Advance online publication. doi:10.1109/JSYST.2021.3077594
- Georgilakis, P. S., & Hatziargyriou, N. D. (2013, August). Optimal Distributed Generation Placement in Power Distribution Networks: Models, Methods, and Future Research. *IEEE Transactions on Power Systems*, 28(3), 3420–3428. doi:10.1109/TPWRS.2012.2237043
- Ghosh, S., Ghoshal, S. P., & Ghosh, S. (2010). Optimal sizing and placement of distributed generation in a network system. *International Journal of Electrical Power & Energy Systems*, 32(8), 849–856. doi:10.1016/j.ijepes.2010.01.029
- Jaiswal & Shrivastava. (n.d.). A PSO based Search for Optimal Tuning and Fixing of UPFC to Improve Usefulness of Distribution System. *Journal of Intelligent and Fuzzy System*. 10.3233/JIFS-169783,2018

- Jaiswal, S. P., Shrivastava, V., & Palwalia, D. K. (2020). Opportunities and challenges of PV technology in power system. *Materials Today: Proceedings*. Advance online publication. doi:10.1016/j.matpr.2020.01.269
- Katyara, S., Shaikh, M. F., Shaikh, S., Khand, Z. H., Staszewski, L., Bhan, V., Majeed, A., Shah, M. A., & Zbigniew, L. (2021). Leveraging a Genetic Algorithm for the Optimal Placement of Distributed Generation and the Need for Energy Management Strategies Using a Fuzzy Inference System". *Electronics (Basel)*, 10(2), 172. doi:10.3390/electronics10020172
- Kumar, R. S., Raghav, L. P., Raju, D. K., & Singh, A. R. (2021). Intelligent demand-side management for optimal energy scheduling of grid-connected microgrids. *Applied Energy*, 285, 116435. Advance online publication. doi:10.1016/j.apenergy.2021.116435
- Le, D. A., & Dieu, N. (2016). Cuckoo Search Algorithm for Minimization of Power Loss and Voltage Deviation. *International Journal of Energy Optimization and Engineering*, 5(1), 23–34. Advance online publication. doi:10.4018/IJEOE.2016010102
- Murty, V. V. V. S. N., & Kumar, A. (2019). Optimal DG integration and network reconfiguration in microgrid system with realistic time varying load model using hybrid optimization. *IET Smart Grid*, 2(2), 192–202. doi:10.1049/iet-stg.2018.0146
- Nguyen, T. P., Dieu, V. N., & Vasant, P. (2017). Symbiotic Organism Search Algorithm for Optimal Size and Siting of Distributed Generators in Distribution Systems. *International Journal of Energy Optimization and Engineering*, 6(3), 1–28. Advance online publication. doi:10.4018/IJEOE.2017070101
- Phonrattanasak, P. (2010). Optimal placement of DG using multiobjective particle swarm optimization. *ICMET 2010 - 2010 International Conference on Mechanical and Electrical Technology Proceedings*, 342–346. doi:10.1109/ICMET.2010.5598377
- Prabha, D. R., & Jayabarathi, T. (2014). Determining the optimal location and sizing of distributed generation unit using Plant Growth Simulation Algorithm in a radial distribution network. *WSEAS Trans. Syst*, 13, 543–550.
- Ramavt, Goel, Jaiswal, & Shrivastava. (n.d.). *Optimal Location and Sizing of DG in Distribution System and its Cost-Benefit analysis*. Advances in Intelligent Systems and Computing. Springer 10.1007/978-981-13-1819-1_11
- Ramesh, L., Chowdhury, S. P., Chowdhury, S., Song, Y. H., & Natarajan, A. A. (2008). Voltage stability analysis and real power loss reduction in distributed distribution system. Transmission and distribution conference and exposition, 1-6. doi:10.1109/TDC.2008.4517070
- Ras Guerriche & Bouktir. (2015). Optimal Allocation and Sizing of Distributed Generation with Particle Swarm Optimization Algorithm for Loss Reduction. *Revue des Sciences et de la Technologie*, 6(1), 59–69.
- Roslan, M. F., Hannan, M. A., & Pin Jern Ker, R. A. (2021). Scheduling controller for microgrids energy management system using optimization algorithm in achieving cost-saving and emission reduction. *Applied Energy*, 292, 116883. Advance online publication. doi:10.1016/j.apenergy.2021.116883
- Saidu, M. M., & Jaiswal, S. P. (2020). A survey on Automation of microgrid and micro distributed generation. *Materials Today: Proceedings*. doi:10.1016/j.matpr.2020.11.404.4
- Singh & Jaiswal. (2021). Enhancement of ATC of micro grid by optimal placement of TCSC. *Materials Today: Proceedings*, 34(3), 787–792. doi:10.1016/j.matpr.2020.05.161
- Thakar, S., Vijay, A. S., & Doolla, S. (2019). System reconfiguration in microgrids. *Sustainable Energy. Grids and Networks*, 17, 100191. doi:10.1016/j.segan.2019.100191
- Tyagi, A., & Verma, A. (2016). Comparative study of IHS and BF-DE algorithm for optimal DG placement. *2016 International Conference on Energy Efficient Technologies for Sustainability (ICEETS)*, 336-340. doi:10.1109/ICEETS.2016.7583776
- Vasant, P., Zelinka, I., & Weber, G.-W. (2018). *Intelligent Computing & Optimization*. In *Conference proceedings ICO*. Springer. <https://link.springer.com/book/10.1007/978-3-030-00979-3>
- Vasant, P., Zelinka, I., & Weber, G.-W. (2019). *Intelligent Computing and Optimization*. In *Proceedings of the 2nd International Conference on Intelligent Computing and Optimization*. Springer International Publishing. <https://link.springer.com/book/10.1007/978-3-030-33585-4>

Vasant, P., Zelinka, I., & Weber, G.-W. (2020). Intelligent Computing and Optimization. *Proceedings of the 3rd International Conference on Intelligent Computing and Optimization*. <https://link.springer.com/book/10.1007/978-3-030-68154>

Veerasha, Maruthi Prasanna, Likith Kumar, & Ananthapadmanabha. (2021). An adaptive power system management with DG placement and cluster-based load forecasting by CS, K-means and ANN algorithms. *International Journal of Power Electronics*, 13(3). 10.1504/IJPELEC.2021.114466,2021

Yadav, M., & Vijay Kumar, T. V. (2017). Distributed Query Plan Generation using Cuckoo Search Algorithm. *International Journal of Energy Optimization and Engineering*, 6(1), 86–100. Advance online publication. doi:10.4018/IJEOE.2017010105

Yang, Dong, & Zhang. (2021). An enhanced adaptive bat algorithm for microgrid energy scheduling. *Energy*, 232. .10.1016/j.energy.2021.121014

Shiva Puja Jaiswal received the B.Sc. degree in engineering and the M.Tech. degree from the Faculty of Engineering, Dayalbagh Educational Institute, Deemed University, Agra, India, in 2004 and 2007, respectively, and the Ph.D. degree from the Department of Electrical Engineering, Rajasthan Technical University, Kota, India. His research interests include distributed generation, power system protection, and FACTS controllers.

K. Jayachitra completed B.E. in Electronics and Communication Engineering from Jayam College of Engineering and Technology, Tamilnadu in 2002. She completed M.Tech in Telecommunication Engineering from Uttar Pradesh Technical University in 2014. She is currently pursuing Ph D from Sharda University. Her areas of interest include Microstrip Antennas, Wireless Sensor Networks, Structural Health Monitoring, Home Automation and Optimization techniques.