

# Miniaturized Infusion Monitoring System with Weight Sensor (Load Cell) Based on AT-MEGA 328 Microcontroller

Daswara Djajasmita<sup>1a</sup>, M. Reza Hidayat<sup>2b</sup>, Susanto Sambasri<sup>3c</sup>

<sup>1</sup>Medical School Department of Universitas Jenderal Achmad Yani, Indonesia

<sup>2,3</sup>Electrical Engineering School Department of Universitas Jenderal Achmad Yani, Indonesia  
Jl. Terusan Jenderal Soedirman, Cimahi

<sup>a</sup>daswara.sasmita@gmail.com, <sup>b</sup> mreza@lecture.unjani.ac.id, <sup>c</sup>santo,sambasri@gmail.com

---

**Abstract.** The development of medical equipment with advanced technology can provide convenience in providing services to the community. One of the equipment that is in the hospital and most often used is an IV. In its use, manual infusion is used to determine the volume of the infusion and must be monitored every hour or even minute by the nurse. This is considered quite difficult, especially in the era of the Covid-19 pandemic where minimal interaction is required from 2 individuals. This is done by utilizing sensor technology to monitor the patient's condition so that the frequency of the nurses checking the condition of the infusion is getting less. Therefore, in this research, manufactured of an infusion monitoring system using a weight sensor (Load Cell) based on the ATMEGA 328 microcontroller was carried out. The sensor of this monitoring system uses a Load Cell Weight Sensor with the HX711 module which is integrated into the ARDUINO UNO MCU. The output of the system is displayed on a 16 x 2 mm LCD as well as a Macro Excel which will display the percentage value of intravenous fluids in the PC and real-time automatic data logging into the macro excel. The infusion used uses NaCl fluid infusion. The test results of the system as a whole show that the data for measuring levels (%) of intravenous fluids can be sent and displayed on the LCD and PC. The incoming data is converted into a table at certain time intervals according to the user's choice into the operator. The experiment was carried out 10 times by looking at changes in the contents of the infusion fluid over time in 11 stages where the LED lights up when the weight of the infusion reaches 40 - 46 grams. Then, the buzzer and LED have turned on when the weight of the infusion is less than 5 grams. From the experiment, it can be concluded the 10% setpoint alarm works well, i.e. when the infusion load is less than the 1% set point, the buzzer and LED will light up until the intravenous fluid is replaced with a new one.

**Keywords:** Infusion, ARDUINO UNO, Load Cell, HX711, Macro Excel.

---

## 1. Introduction

With the development of more sophisticated medical science and technology, there is data that will be included in health services to the public [1], especially if there is the development of science and technology in the field of medical devices in the era of the Covid-19 pandemic. One of the facilities in the hospital that is most often used is infusion [2]. In the use of manual infusion to determine the volume of the infusion, the nurse should monitor it every hour or even minute [3]. This method, of course, still really needs more manpower to monitor it, especially with the limited number of personnel [4] - [5]. As an effort to overcome this problem, in this study, this research tried to design a device where the working principle of this tool is to monitor the volume of the infusion and provide a warning indicator when the intravenous fluid is in the minimum set point volume. This tool uses the AT-Mega 328 microcontroller as the brain or control to process the input signal and give commands to execute in the form of commands to turn on the buzzer and indicator lights.

Several researches that are used as references in this research are related to the use of microcontrollers in the health sector, namely the development of independent flexible skin patches for transdermal insulin delivery with a new fluid volume sensor to monitor the volume of drugs sent using a load sensor [6]. Then, in the research on the performance, bottles were equipped with accelerometer sensors to monitor and track the load of fluid intake [7]. In the next research, the non-contact

measurement of the liquid level in the infusion bottle was simulated following the ultrasonic signal parameters captured by the HC-SR sensor [8]. Also it used Piezoelectrically actuated self-sensing cantilever sensor for fluid monitoring purposes [9]. Based on previous research, the application of the use of sensors in medical technology development was very important to support better service for patients. For this reason, this research will also use a load sensor in monitoring the volume of intravenous fluids

The research was carried out by designing a schematic diagram composed of a monitoring system configuration using ARDUINO, testing the accuracy of the load sensor, testing the performance of the sensor on the infusion center by adjusting the set points as needed (10%) and paying attention to the condition of the LED indicator and buzzer as well as integrating the monitoring result data to the operator using macro excel. Then, it provides information to the operator in order to know the condition of the intravenous fluid in real time.

## 2. Research Methods

The design of the infusion monitoring system using a load sensor based on the ATMEGA 328 microcontroller is made to collect very critical infusions to be monitored so that the condition of the infusion status can be directly monitored by the hospital nurse (medical expert). This tool is based on the ARDUINO UNO microcontroller, Buzzer and LED as an

indicator if there is pressure exceeding a predetermined set point, and can make it easier for nurses to monitor status conditions via 64.15 x 16 mm LCD in the field or via computer using Macro Excel Software because data from the actual values of infusion can be made automatically stored in Microsoft Excel 2010. The performance of the Infusion monitoring system uses a load sensor based on the ATmega 328 microcontroller as follows, when the infusion monitoring module is loaded by the automatic infusion, the module will read the presentation value of the total that has become plus and bad scores on the 16 x 2 mm LCD. The voltage comes out of the Load Cell sensor and the HX711 Module then coming by the ARDUINO UNO Microcontroller to generate pressure target data information. The measured pressure is displayed on 16 x 2 mm LCD for operator to see infusion presentation value. In addition, ARDUINO UNO sends data to personal computers in the form of Macro Excel Software via serial RX pin data, then the values displayed in the macro excel can be stored in Microsoft Excel. This system is also designed where there is a buzzer and LED as an indicator; if the proportion of infusion exceeds the set point, the buzzer will sound and the LED will flash.

### 2.1. Hardware Design

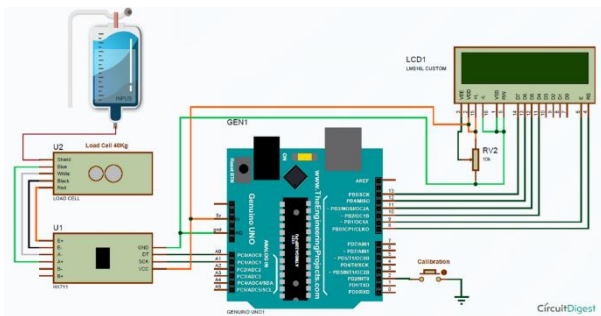

Figure 1. Overall Schematic Circuit

In order to read the percentage of infusion, a weight sensor is used. Load Cell Sensor is able to read weights up to 5 Kg. This sensor output is then entered into the HX711 module with the output in the form of a serial data output. This Single Point Load Cell is used in small jewelry scales and kitchen scales. It is mounted by bolting down the end of the load cell where the wires are attached and applying force on the other end where the force applied is not critical, as the load cell measures a shearing effect on the beam, not the bending of the beam. After the load cell sends the weigh results from the object of the infusion fluid that exceeds the maximum weight limit in the form of an analog signal, it is converted into a digital signal form, as shown above DOUT, and PD\_SCK gets input from the load cell where the weight sensor module will change from analog signal to digital signal with forms such as 1, 2 and so on. The outline of the picture below is a picture of the change from analog signal to digital signal. The configuration of whole system is shown in figure 1 above [10].

LCD is used to monitor the percentage of infusion by displaying the set point value and the actual percentage value of the infusion. Buzzer serves to provide a warning sound when the pressure exceeds a predetermined set point. The LED also serves to provide a flashing light warning when the pressure

exceeds a predetermined set point. The whole schematic circuit is a combination of all sensors, displays and controllers or ARDUINO so that this system can work according to its function.

### 2.2. Software Design

In designing this software, a program that has an outline function is needed. The program is the reading of the load cell sensor so that it can be read in the serial of the internal monitor and 16 x 2 mm LCD. Then, a command appears to display the actual data on LDC 16 x 2 mm. Next is the command to activate the Buzzer and the LED when the actual value is above the predetermined set point. In macro excel, the command opens and displays the actual value of serial monitor reading in macro excel. There is also a command to open Microsoft Excel 2010. Finally, a command is made to make continues value in Microsoft Excel 2010 [6]. For the whole monitoring system with the load cell sensor for the HX711 module, enter the program listing as from the following figure 2 and 3.

```
#include "HX711.h"
#include <LiquidCrystal.h>
LiquidCrystal lcd(12, 11, 5, 4, 3, 2);
#define DOUT A2
#define CLK A3
HX711 berat(DOUT, CLK);
float hasil;
int lampu = 8;
int Buzzer = 7;
int sts ;
void setup()
{
  pinMode ( lampu, OUTPUT );
  pinMode ( Buzzer, OUTPUT );
  lcd.begin(16, 2);
  Serial.begin(9600);
  lcd.clear();
  lcd.setCursor(0, 0);
  lcd.print("Baca Nilai");
  lcd.print(berat.read());
  lcd.print(" AI ");
  lcd.setCursor(0,1);
  lcd.print("Mengkalibrasi");
  berat.set_scale(45000);
  Serial.print("Membaca nilai analog");
  Serial.println(berat.read());
  Serial.println("Jangan menambahkan benda");
  Serial.println("Mengkalibrasi...");
  Serial.println("...");
  berat.set_scale(45000);
  berat.tare(5);
  Serial.println("Siap untuk menimbang");
  Serial.println("LABEL,Computer Time,Monitoring Infus ,Unit, Status");
}
```

Figure 2. Program of the monitoring system (1)

```
lcd.clear(); //Perintah ini untuk menghapus seluruh tampilan yang ada di LCD. Baris 1
lcd.setCursor(0,0); //Untuk menulis karakter pada posisi tertentu
lcd.print("INFUS :"); //Menulis ke LCD dengan karakter yang ada dalam tanda kurung()
lcd.print(hasil, 0);
lcd.print(" % ");
lcd.setCursor(0,1);
lcd.print("Set Poin = 10%");
delay ( 1000 );
Serial.print("Berat ");
Serial.print(hasil, 0);
Serial.println(" Gram");
delay(1000);
Serial.print("DATA, TIME,");
Serial.print(hasil, 0);
Serial.print(",");
Serial.println("%");
if ( hasil <= 10){
  digitalWrite(lampu, HIGH);
  delay ( 500 );
  digitalWrite(lampu, LOW);
}
if ( hasil <= 10){
  digitalWrite(Buzzer, HIGH);
  delay ( 500 );
  digitalWrite(Buzzer, LOW);
}
}
```

Figure 2. Program of the monitoring system (2)

### 3. Result and Discussion

Before measuring the sensitivity of the load sensor, the calibration process has been done with simple formula. It is usually used to convert the measured mv/V output from the load cell to the measured force:

$$\text{Measured Force} = A * \text{Measured mV/V} + B \text{ (offset)} \quad (1)$$

$$\text{To find A we use: } A = \text{Capacity} / \text{Rated Output} \quad (2)$$

Since the Offset is quite variable between individual load cells, it is necessary to calculate the offset for each sensor.

The initial test is a sensor test which aims to determine the no-load weight where the calculation without using a load will show 0 grams or a tolerance of 1 gram, so that when the load is given, the infusion will show a weight at 545 grams or a tolerance of 543 grams. The weight of the infusion has previously been weighed with analog scales by showing at 545 grams.

**Table 1.** Result the accuracy of load sensor readings

No.	Initial Weight (gram)	Weight .set_scale	Load Reading Results (gram)
1	0 ( gram )	4500	0 – 1 ( gram )
2	0 ( gram )	2000	1 – 2 ( gram )
3	545 ( gram )	4500	543 – 545 ( gram )
4	545 ( gram )	4500	544 – 545 ( gram )
5	545 ( gram )	4500	544 – 545 ( gram )
6	545 ( gram )	4500	544 – 545 ( gram )

Result of weight is obtained with weight = weight, set\_scale (45000) x weight of tare (5) x units of grams (100). 1 in this case returns 1 decimal point (,) [11] – [12]. From the results of the calibration test at table 1, the ideal value is obtained to get a value of 0 grams to a tolerance of 1 gram; it must be inputted with weight, set\_scale (4500), and tare weight (5), so that when the load is given, the infusion fluid will get the ideal weight at 543 grams to 545 grams. The next step is the conversion of the weight read by the load cell module in the form of grams and converted into a percentage (%) where in a full infusion of 450 grams = 100% and in a low state 0 grams = 0% which will then be displayed in LCD and can be monitored by Macro excel. The result of this process shown in Table 2.

**Table 2.** Convert Gram to Percentage

No.	Infusion fluids (gram)	Conversion (%)	Output
1	450	99	---
2	225	48	---
3	50	10	LED
4	0	0	Buzzer & LED

From the results of the data above, it can be concluded that there is a tolerance of 1 to 3% for each gram to percent conversion where if the set point is greater than 15%, there will be no command to turn on the LED or buzzer. Moreover, if the set point shows below 15%, the LED will light up. Meanwhile, if the set point shows below 10%, then the LED and buzzer will light up simultaneously, indicating that the infusion condition is running low.

The final step in designing this program system is to test it as a whole. After connecting the Arduino Uno to the computer using a USB cable, the PC is automatically handled by Arduino along with the port used. After that, the Sketch sheet program says "Done compiling". This indicates that the program is running well. The display of this stage can be seen in Figure 4.



**Figure 4.** Program compilation

The process of testing the series and programs contained in the Arduino on the monitoring system that has been integrated with the Macro excel Program has been realized by paying attention to the ports used by Arduino, namely by accessing the Ports menu (COM & LPT). With this, the port that should be used can be determined. When the interconnection process is successful, the next step is to enter the Arduino program in which when entering the program on the Macro excel, the port used must be the same as the one used by Arduino on the serial port menu. When the series and upload process of the program has been completed, the second stage, which is connected to the Macro excel Program, is carried out. The result of the Macro excel Program can then be opened on the PC operator that has been integrated from the program that has been made with Arduino. In displaying the monitoring of experimental results with the Macro excel program, it is done by accessing the "start" menu.

Based on the results of observations from the performance testing of the IV fluid monitoring system, each experiment was carried out for 570 minutes (until the liquid was used up) with 22-23 drops per minute (1 minute approximately 500ml). This was done for 10 times. The results of the observations can be seen in the following Table 3. The LCD display at measurement process form hardware realization can be seen from Figure 5. The result of data collection from monitoring process done from 10 times experiment for 570 minutes in macro excel can be seen from Figure 6.

**Table 3.** Overall monitoring system performance results

Time (minutes)	Gram	%	Output
0	545	100	
60	496 - 486	91 - 88	
120	442-432	81 - 78	
180	383 - 370	71 - 68	
240	333 - 320	60 - 56	
300	275 - 260	50 - 47	
360	225 - 216	39 - 35	
420	167 - 151	28 - 25	
480	103 - 90	17 - 15	
540	46-40	7-4	LED on
570	4 - 0	1 - 0	Buzzer and LED On

From Table 3, it can be concluded that the system works according to the set point setting where the infusion has decreased weight by 10 - 12% every hour until when the percentage value is below 10%, the LED lights up indicating the condition of the liquid is running low and when the percentage value of the weight of the infusion is below 1 %, then the LED and the buzzer will light up indicating that the intravenous fluid must be replaced immediately. In 10 trials, the weight of the infusion detected by the system can vary, such as when the trial lasted for 60 minutes, the weight of the intravenous fluid read was in the range 496 - 486 grams (or in a percentage in the range 88 - 91%). The condition of the LED is on and the Buzzer is also on. It varies but it is still within the specifications according to the programming.



**Figure 5.** The entire range of hardware during the initial infusion (LCD Display)

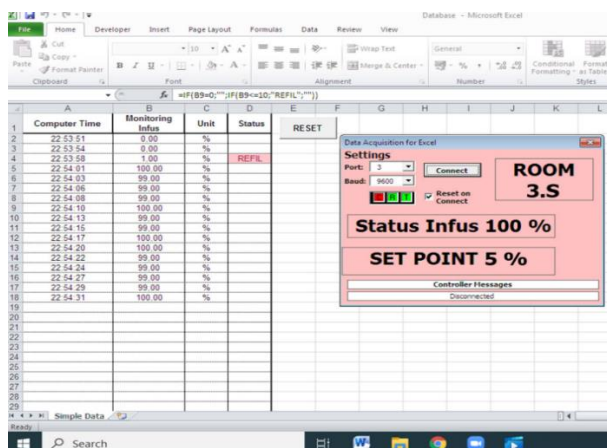

**Figure 6.** Display of monitoring results in macro excel

**4. Conclusion**

From the measurement results it can be concluded that before the experiment, it is necessary to calibrate to determine the initial value (0), where to obtain this value, it is necessary to calculate the calculation "Result of weight = weight. Scale set (45,000) x tare weight (5) x units of grams (100) "into the program on the arduino uno. From the results, it is known that based on the set point configuration where if the proportion of the result is <10%, the LED will light up repeatedly and if the proportion is <1%, the LED and buzzer will turn on repeatedly.

From the results of 10 experiments, testing the performance of the monitoring system that the load sensor detects the volume of intravenous fluids less than 10% (starting from around 40 - 46) grams makes the sensor send information to the microcontroller so that the LED lights up. This happened about 540 minutes after the experiment began. When the buzzer turns on, this occurs when the experiment runs 570 minutes (30 minutes after the LED lights up) and the percentage of volume of intravenous fluids is 4% (about 4 grams). The infusion reading has also succeeded in fixing the macro which stores the results of monitoring data in real time every minute. Data recording programs are capable of storing data sent from the serial port with chronological numbering without interference from serial port data.

**References**

- [1] Humid A. Toliyat, Emil Levi and Mona Raina, "A Review of RFO Induction Motor Parameter Estimation Techniques", *IEEE Transactions on Energy Conversion*, vol. 18, no. 2, pp. 271-283, June 2003.
- [2] J. Guo, P. Hu, L. Li and R. Wang, "Design of automatic steering controller for trajectory tracking of unmanned vehicles using genetic algorithms", *IEEE Transactions on Vehicular Technology*, vol. 61, no. 7, Sept. 2012.
- [3] D.K. Chwa, "Fuzzy adaptive tracking control of wheeled mobile robots with state-dependent kinematic and dynamic disturbances", *IEEE Transactions on Fuzzy Systems*, vol. 20, no. 3, June 2012.
- [4] A. Roennau, G. Heppner, T. Kerscher and R. Dillmann, "Fault Diagnosis and System Status Monitoring for a Six-Legged Walking Robot", *2011 IEEE/ASME International Conference on Advanced Intelligent Mechatronics (AIM2011)*, July 3–7, 2011.
- [5] S. Manoiu Olaru, M. Nitulescu and Hexapod Robot, "Mathematical support for modeling and control", *Proceedings of the 15th International Conference on System Theory Control and Computing ICSTCC 2011*, vol. 1, Octombrie, 2011.
- [6] Wang, H., Wang, T. and Lee, C., Self-powered liquid volume sensor aiming at lab-on-chip applications. 2016.
- [7] Dong, B., Gallant, R. and Biswas, S., A self-monitoring water bottle for tracking liquid intake., *2014 IEEE Healthcare Innovation Conference (HIC)*. 2014.
- [8] Ying Chen, Huqiu Liu, Longbin Liu and Li Gao. Intelligent liquid drip rate monitoring and early warning systems. 2017.
- [9] Pfusterschmied, G., Kucera, M., Ruiz-Díez, V., Bittner, A., Sánchez-Rojas, J.L. and Schmid, U., Multi roof tile-shaped vibration modes in mems cantilever sensors for liquid monitoring purposes. 2015

- [10] W. Chen, K. Kong and M. Tomizuka, "Hybrid adaptive friction compensation of indirect drive trains", *Proceedings of 2009 ASME Dynamic Systems and Control Conference*, Oct. 2009.
- [11] H. Fu, K. Zhou, P. Saffari, C. Mou, L. Zhang, S. He, et al., "Microchanneled chirped Fiber Bragg grating formed by Femtosecond laser-aided chemical etching for refractive index and temperature measurements", *IEEE Photon. Technol. Lett.*, vol. 20, no. 19, pp. 1609-1611, 2008.
- [12] F. Umbrecht et al., "A Wireless Implantable Passive Strain Sensor System", *IEEE Sensors*, pp. 20-23, 2005.